

REV.	SPECIFICATION	ECN NO.	APPD.

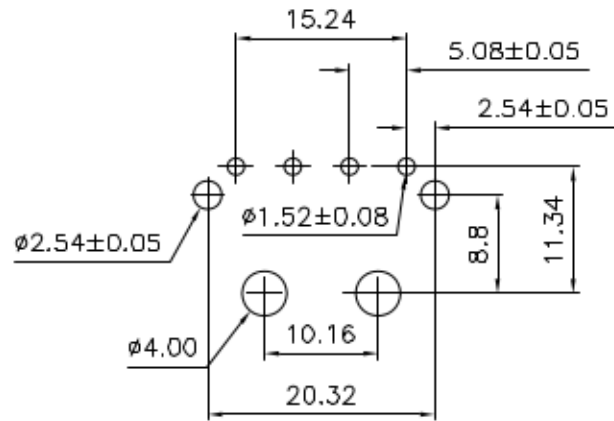
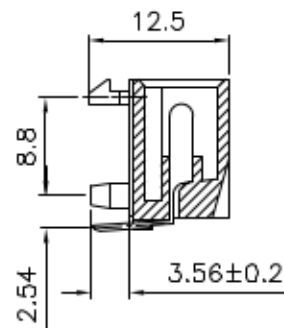
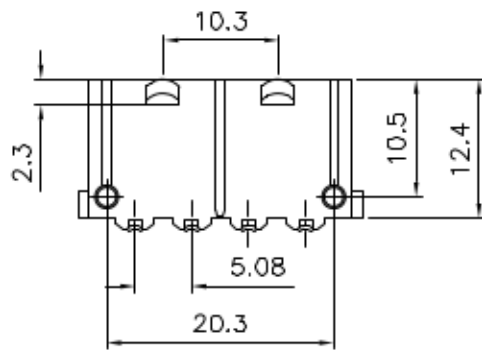
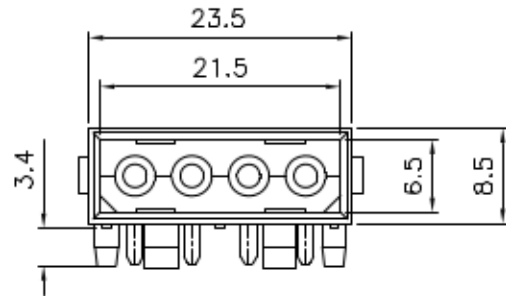

P.C.Board Layout

Material:

Housing: Thermoplastic Polyester UL94V-2.

Contacts: Copper Alloy

Electrical Characteristics:

Current Rating: 7 AMP.

Dielectric Withstanding Voltage: AC 1500V For 1 minute.

Insulator Resistance: 1000MΩ min.

Current Resistance: 20mΩ max.

Operating Temperature: -25°C~+85°C .

***RoHS Compliant**

4874- Series 04 No.of Pin Count T T: Tin Plated R R: Right Angle A A: Tray Package

Tolerances	Dwg. No.	4874D01002	Title:			
x = ±0.5	Projection		4874 Series			
.x = ±0.25	Unit	mm	Scale	1:1	Wafer Pitch 5.08mm	
.xx = ±0.15	Drawn By	Peggy12/03'12	0764	P/N: 4874-04TRA		
				SHEET	1/1	Ver. No.
						B2