



# ±1.5g, ±6g Three Axis Low-g Micromachined Accelerometer

The MMA7361LC is a low power, low profile capacitive micromachined accelerometer featuring signal conditioning, a 1-pole low pass filter, temperature compensation, self test, 0g-Detect which detects linear freefall, and g-Select which allows for the selection between 2 sensitivities. Zero-g offset and sensitivity are factory set and require no external devices. The MMA7361LC includes a Sleep Mode that makes it ideal for handheld battery powered electronics.

## Features

- 3mm x 5mm x 1.0mm LGA-14 Package
- Low Current Consumption: 400  $\mu$ A
- Sleep Mode: 3  $\mu$ A
- Low Voltage Operation: 2.2 V – 3.6 V
- High Sensitivity (800 mV/g @ 1.5g)
- Selectable Sensitivity ( $\pm$ 1.5g,  $\pm$ 6g)
- Fast Turn On Time (0.5 ms Enable Response Time)
- Self Test for Freefall Detect Diagnosis
- 0g-Detect for Freefall Protection
- Signal Conditioning with Low Pass Filter
- Robust Design, High Shocks Survivability
- RoHS Compliant
- Environmentally Preferred Product
- Low Cost

## Typical Applications

- 3D Gaming: Tilt and Motion Sensing, Event Recorder
- HDD MP3 Player: Freefall Detection
- Laptop PC: Freefall Detection, Anti-Theft
- Cell Phone: Image Stability, Text Scroll, Motion Dialing, E-Compass
- Pedometer: Motion Sensing
- PDA: Text Scroll
- Navigation and Dead Reckoning: E-Compass Tilt Compensation
- Robotics: Motion Sensing

ORDERING INFORMATION				
Part Number	Temperature Range	Package Drawing	Package	Shipping
MMA7361LCT	-40 to +85°C	1977-01	LGA-14	Tray
MMA7361LCR1	-40 to +85°C	1977-01	LGA-14	7" Tape & Reel
MMA7361LCR2	-40 to +85°C	1977-01	LGA-14	13" Tape & Reel

## MMA7361LC

**MMA7361LC: XYZ AXIS  
 ACCELEROMETER**  
 $\pm$ 1.5g,  $\pm$ 6g

### Bottom View

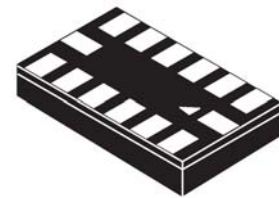

**14 LEAD  
 LGA  
 CASE 1977-01**

### Top View

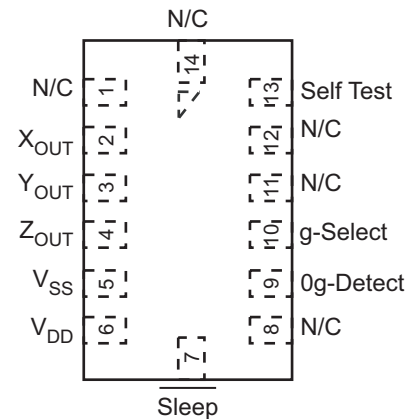

**Figure 1. Pin Connections**

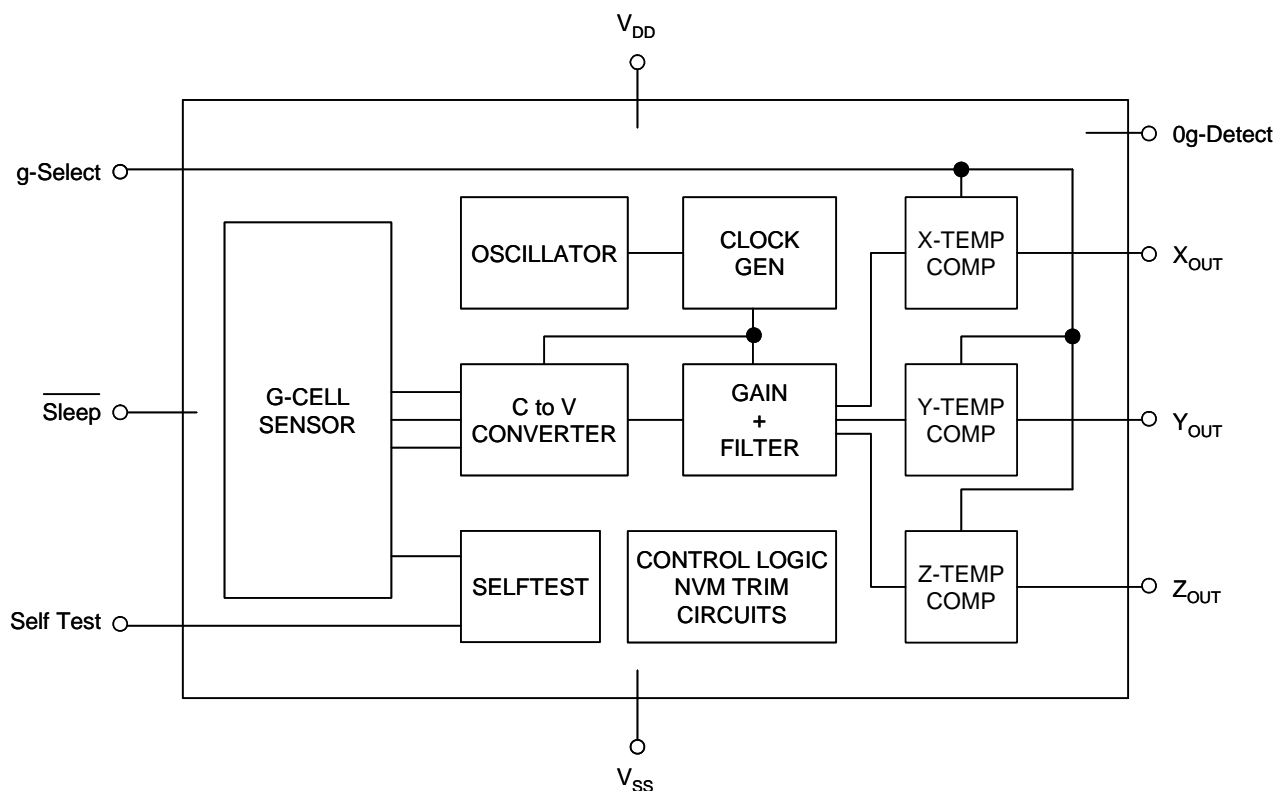

Figure 2. Simplified Accelerometer Functional Block Diagram

Table 1. Maximum Ratings

(Maximum ratings are the limits to which the device can be exposed without causing permanent damage.)

Rating	Symbol	Value	Unit
Maximum Acceleration (all axis)	$g_{max}$	$\pm 5000$	g
Supply Voltage	$V_{DD}$	-0.3 to +3.6	V
Drop Test <sup>(1)</sup>	$D_{drop}$	1.8	m
Storage Temperature Range	$T_{stg}$	-40 to +125	°C

1. Dropped onto concrete surface from any axis.

## ELECTRO STATIC DISCHARGE (ESD)

**WARNING: This device is sensitive to electrostatic discharge.**

Although the Freescale accelerometer contains internal 2000 V ESD protection circuitry, extra precaution must be taken by the user to protect the chip from ESD. A charge of over 2000 volts can accumulate on the human body or associated test equipment. A charge of this magnitude can

alter the performance or cause failure of the chip. When handling the accelerometer, proper ESD precautions should be followed to avoid exposing the device to discharges which may be detrimental to its performance.

**Table 2. Operating Characteristics**Unless otherwise noted:  $-40^{\circ}\text{C} \leq T_A \leq 85^{\circ}\text{C}$ ,  $2.2\text{ V} \leq V_{\text{DD}} \leq 3.6\text{ V}$ , Acceleration = 0g, Loaded output<sup>(1)</sup>

Characteristic	Symbol	Min	Typ	Max	Unit
Operating Range <sup>(2)</sup>					
Supply Voltage <sup>(3)</sup>	$V_{\text{DD}}$	2.2	3.3	3.6	V
Supply Current <sup>(4)</sup>	$I_{\text{DD}}$	—	400	600	$\mu\text{A}$
Supply Current at Sleep Mode <sup>(4)</sup>	$I_{\text{DD}}$	—	3	10	$\mu\text{A}$
Operating Temperature Range	$T_A$	-40	—	+85	$^{\circ}\text{C}$
Acceleration Range, X-Axis, Y-Axis, Z-Axis					
g-Select: 0	$g_{\text{FS}}$	—	$\pm 1.5$	—	g
g-Select: 1	$g_{\text{FS}}$	—	$\pm 6.0$	—	g
Output Signal					
Zero-g ( $T_A = 25^{\circ}\text{C}$ , $V_{\text{DD}} = 3.3\text{ V}$ ) <sup>(5), (6)</sup>	$V_{\text{OFF}}$				
XY		1.485	1.65	1.815	V
Z		1.32	1.65	1.815	v
Zero-g <sup>(4)</sup>	$V_{\text{OFF}}, T_A$	-2.0	$\pm 0.5$	+2.0	$\text{mg}/^{\circ}\text{C}$
Sensitivity ( $T_A = 25^{\circ}\text{C}$ , $V_{\text{DD}} = 3.3\text{ V}$ )					
1.5g	$S_{1.5\text{g}}$	740	800	860	$\text{mV}/\text{g}$
6g	$S_{6\text{g}}$	190.6	206	221.5	$\text{mV}/\text{g}$
Sensitivity <sup>(4)</sup>	$S, T_A$	-0.0075	$\pm 0.002$	+0.0075	$\%/^{\circ}\text{C}$
Bandwidth Response					
XY	$f_{-3\text{dBXY}}$	—	400	—	Hz
Z	$f_{-3\text{dBZ}}$	—	300	—	Hz
Output Impedance	$Z_{\text{O}}$	—	32	—	$\text{k}\Omega$
0g-Detect	$0g_{\text{detect}}$	-0.4	0	+0.4	g
Self Test					
Output Response					
$X_{\text{OUT}}, Y_{\text{OUT}}$	$\Delta g_{\text{STXY}}$	+0.05	-0.1	—	g
$Z_{\text{OUT}}$	$\Delta g_{\text{STZ}}$	+0.8	+1.0	+1.2	g
Input Low	$V_{\text{IL}}$	$V_{\text{SS}}$	—	$0.3 V_{\text{DD}}$	V
Input High	$V_{\text{IH}}$	$0.7 V_{\text{DD}}$	—	$V_{\text{DD}}$	V
Noise					
Power Spectral Density RMS (0.1 Hz – 1 kHz) <sup>(4)</sup>	$n_{\text{PSD}}$	—	350	—	$\mu\text{g}/\sqrt{\text{Hz}}$
Control Timing					
Power-Up Response Time <sup>(7)</sup>	$t_{\text{RESPONSE}}$	—	1.0	2.0	ms
Enable Response Time <sup>(8)</sup>	$t_{\text{ENABLE}}$	—	0.5	2.0	ms
Self Test Response Time <sup>(9)</sup>	$t_{\text{ST}}$	—	2.0	5.0	ms
Sensing Element Resonant Frequency					
XY	$f_{\text{GCELLXY}}$	—	6.0	—	kHz
Z	$f_{\text{GCELLZ}}$	—	3.4	—	kHz
Internal Sampling Frequency	$f_{\text{CLK}}$	—	11	—	kHz
Output Stage Performance					
Full-Scale Output Range ( $I_{\text{OUT}} = 3\ \mu\text{A}$ )	$V_{\text{FSO}}$	$V_{\text{SS}}+0.1$	—	$V_{\text{DD}}-0.1$	V
Nonlinearity, $X_{\text{OUT}}, Y_{\text{OUT}}, Z_{\text{OUT}}$	$NL_{\text{OUT}}$	-1.0	—	+1.0	%FSO
Cross-Axis Sensitivity <sup>(10)</sup>	$V_{\text{XY}, \text{XZ}, \text{YZ}}$	-5.0	—	+5.0	%

- For a loaded output, the measurements are observed after an RC filter consisting of an internal 32 k $\Omega$  resistor and an external 3.3 nF capacitor (recommended as a minimum to filter clock noise) on the analog output for each axis and a 0.1  $\mu\text{F}$  capacitor on  $V_{\text{DD}} - \text{GND}$ . The output sensor bandwidth is determined by the Capacitor added on the output.  $f = 1/2\pi * (32 \times 10^3) * C$ .  $C = 3.3\text{ nF}$  corresponds to  $\text{BW} = 1507\text{ HZ}$ , which is the minimum to filter out internal clock noise.
- These limits define the range of operation for which the part will meet specification.
- Within the supply range of 2.2 and 3.6 V, the device operates as a fully calibrated linear accelerometer. Beyond these supply limits the device may operate as a linear device but is not guaranteed to be in calibration.
- This value is measured with g-Select in 1.5g mode.
- The device can measure both + and – acceleration. With no input acceleration the output is at midsupply. For positive acceleration the output will increase above  $V_{\text{DD}}/2$ . For negative acceleration, the output will decrease below  $V_{\text{DD}}/2$ .
- For optimal 0g offset performance, adhere to AN3484 and AN3447
- The response time between 10% of full scale  $V_{\text{DD}}$  input voltage and 90% of the final operating output voltage.
- The response time between 10% of full scale Sleep Mode input voltage and 90% of the final operating output voltage.
- The response time between 10% of the full scale self test input voltage and 90% of the self test output voltage.
- A measure of the device's ability to reject an acceleration applied 90° from the true axis of sensitivity.

## PRINCIPLE OF OPERATION

The Freescale accelerometer is a surface-micromachined integrated-circuit accelerometer.

The device consists of a surface micromachined capacitive sensing cell (g-cell) and a signal conditioning ASIC contained in a single package. The sensing element is sealed hermetically at the wafer level using a bulk micromachined cap wafer.

The g-cell is a mechanical structure formed from semiconductor materials (polysilicon) using semiconductor processes (masking and etching). It can be modeled as a set of beams attached to a movable central mass that move between fixed beams. The movable beams can be deflected from their rest position by subjecting the system to an acceleration (Figure 3).

As the beams attached to the central mass move, the distance from them to the fixed beams on one side will increase by the same amount that the distance to the fixed beams on the other side decreases. The change in distance is a measure of acceleration.

The g-cell beams form two back-to-back capacitors (Figure 3). As the center beam moves with acceleration, the distance between the beams changes and each capacitor's value will change, ( $C = A\epsilon/D$ ). Where A is the area of the beam,  $\epsilon$  is the dielectric constant, and D is the distance between the beams.

The ASIC uses switched capacitor techniques to measure the g-cell capacitors and extract the acceleration data from the difference between the two capacitors. The ASIC also signal conditions and filters (switched capacitor) the signal, providing a high level output voltage that is ratiometric and proportional to acceleration.

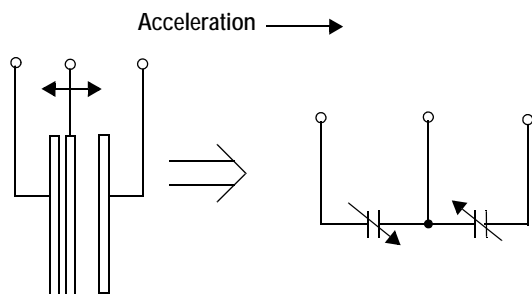

Figure 3. Simplified Transducer Physical Model

## SPECIAL FEATURES

### 0g-Detect

The sensor offers a 0g-Detect feature that provides a logic high signal when all three axes are at 0g. This feature enables the application of Linear Freefall protection if the signal is connected to an interrupt pin or a poled I/O pin on a microcontroller.

### Self Test

The sensor provides a self test feature that allows the verification of the mechanical and electrical integrity of the accelerometer at any time before or after installation. This feature is critical in applications such as hard disk drive

protection where system integrity must be ensured over the life of the product. Customers can use self test to verify the solderability to confirm that the part was mounted to the PCB correctly. To use this feature to verify the 0g-Detect function, the accelerometer should be held upside down so that the Z-axis experiences -1g. When the self test function is initiated, an electrostatic force is applied to each axis to cause it to deflect. The X- and Y-axis are deflected slightly while the Z-axis is trimmed to deflect 1g. This procedure assures that both the mechanical (g-cell) and electronic sections of the accelerometer are functioning.

### g-Select

The g-Select feature allows for the selection between two sensitivities. Depending on the logic input placed on pin 10, the device internal gain will be changed allowing it to function with a 1.5g or 6g sensitivity (Table 3). This feature is ideal when a product has applications requiring two different sensitivities for optimum performance. The sensitivity can be changed at anytime during the operation of the product. The g-Select pin can be left unconnected for applications requiring only a 1.5g sensitivity as the device has an internal pull-down to keep it at that sensitivity (800 mV/g).

Table 3. g-Select Pin Description

g-Select	g-Range	Sensitivity
0	1.5g	800 mV/g
1	6g	206 mV/g

### Sleep Mode

The 3 axis accelerometer provides a Sleep Mode that is ideal for battery operated products. When Sleep Mode is active, the device outputs are turned off, providing significant reduction of operating current. A low input signal on pin 7 (Sleep Mode) will place the device in this mode and reduce the current to 3  $\mu$ A typ. For lower power consumption, it is recommended to set g-Select to 1.5g mode. By placing a high input signal on pin 7, the device will resume to normal mode of operation.

### Filtering

The 3 axis accelerometer contains an onboard single-pole switched capacitor filter. Because the filter is realized using switched capacitor techniques, there is no requirement for external passive components (resistors and capacitors) to set the cut-off frequency.

### Ratiometricity

Ratiometricity simply means the output offset voltage and sensitivity will scale linearly with applied supply voltage. That is, as supply voltage is increased, the sensitivity and offset increase linearly; as supply voltage decreases, offset and sensitivity decrease linearly. This is a key feature when interfacing to a microcontroller or an A/D converter because it provides system level cancellation of supply induced errors in the analog to digital conversion process.

## BASIC CONNECTIONS

### Pin Descriptions

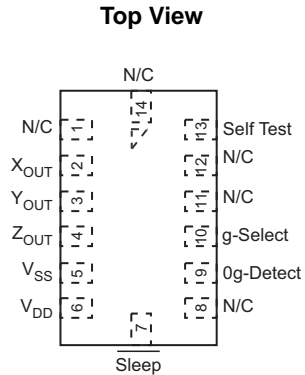

**Figure 4. Pinout Description**

**Table 4. Pin Descriptions**

Pin No.	Pin Name	Description
1	N/C	No internal connection Leave unconnected
2	X <sub>OUT</sub>	X direction output voltage
3	Y <sub>OUT</sub>	Y direction output voltage
4	Z <sub>OUT</sub>	Z direction output voltage
5	V <sub>SS</sub>	Power Supply Ground
6	V <sub>DD</sub>	Power Supply Input
7	Sleep	Logic input pin to enable product or Sleep Mode
8	NC	No internal connection Leave unconnected
9	0g-Detect	Linear Freefall digital logic output signal
10	g-Select	Logic input pin to select g level
11	N/C	Unused for factory trim Leave unconnected
12	N/C	Unused for factory trim Leave unconnected
13	Self Test	Input pin to initiate Self Test
14	N/C	Unused for factory trim Leave unconnected

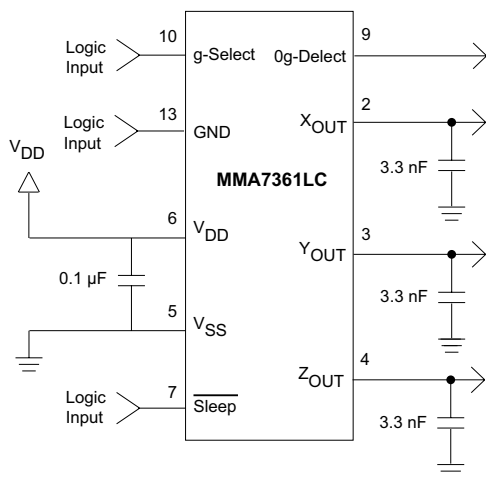

**Figure 5. Accelerometer with Recommended Connection Diagram**

### PCB Layout

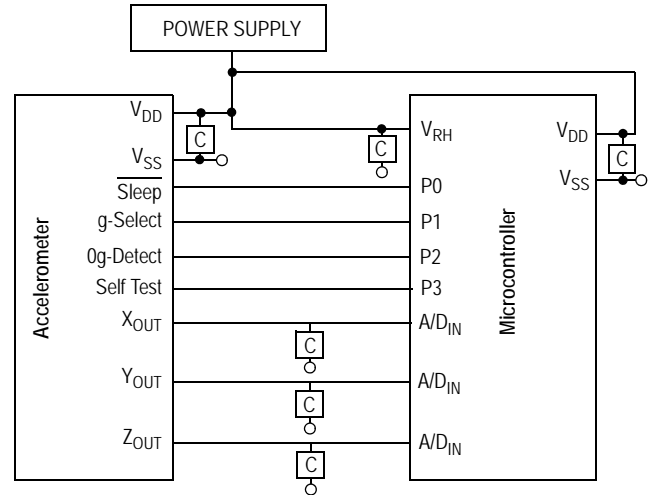

**Figure 6. Recommended PCB Layout for Interfacing Accelerometer to Microcontroller**

#### NOTES:

- Use 0.1  $\mu\text{F}$  capacitor on V<sub>DD</sub> to decouple the power source.
- Physical coupling distance of the accelerometer to the microcontroller should be minimal.
- Place a ground plane beneath the accelerometer to reduce noise, the ground plane should be attached to all of the open ended terminals shown in [Figure 6](#).
- Use a 3.3 nF capacitor on the outputs of the accelerometer to minimize clock noise (from the switched capacitor filter circuit).
- PCB layout of power and ground should not couple power supply noise.
- Accelerometer and microcontroller should not be a high current path.
- A/D sampling rate and any external power supply switching frequency should be selected such that they do not interfere with the internal accelerometer sampling frequency (11 kHz for the sampling frequency). This will prevent aliasing errors.
- 10 M $\Omega$  or higher is recommended on X<sub>OUT</sub>, Y<sub>OUT</sub> and Z<sub>OUT</sub> to prevent loss due to the voltage divider relationship between the internal 32 k $\Omega$  resistor and the measurement input impedance.

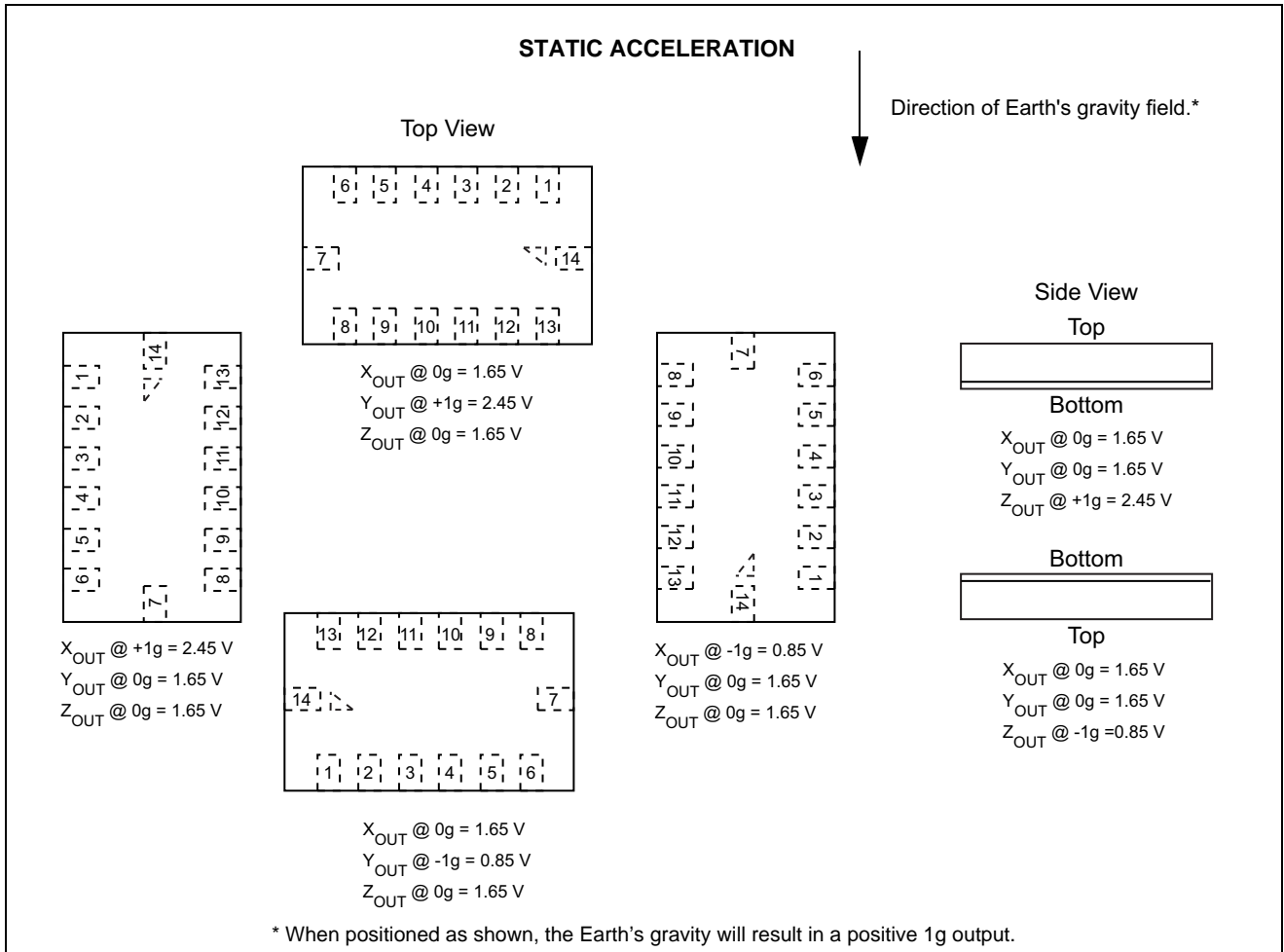
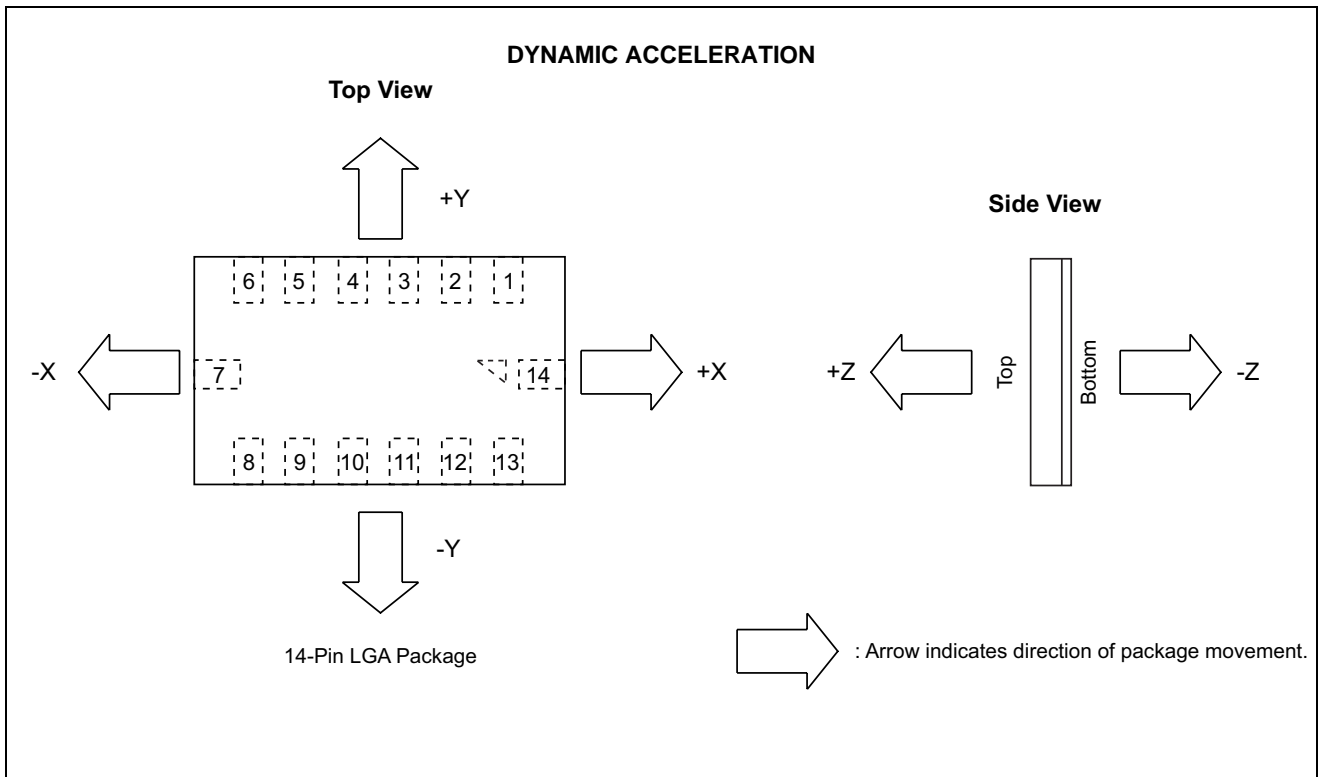

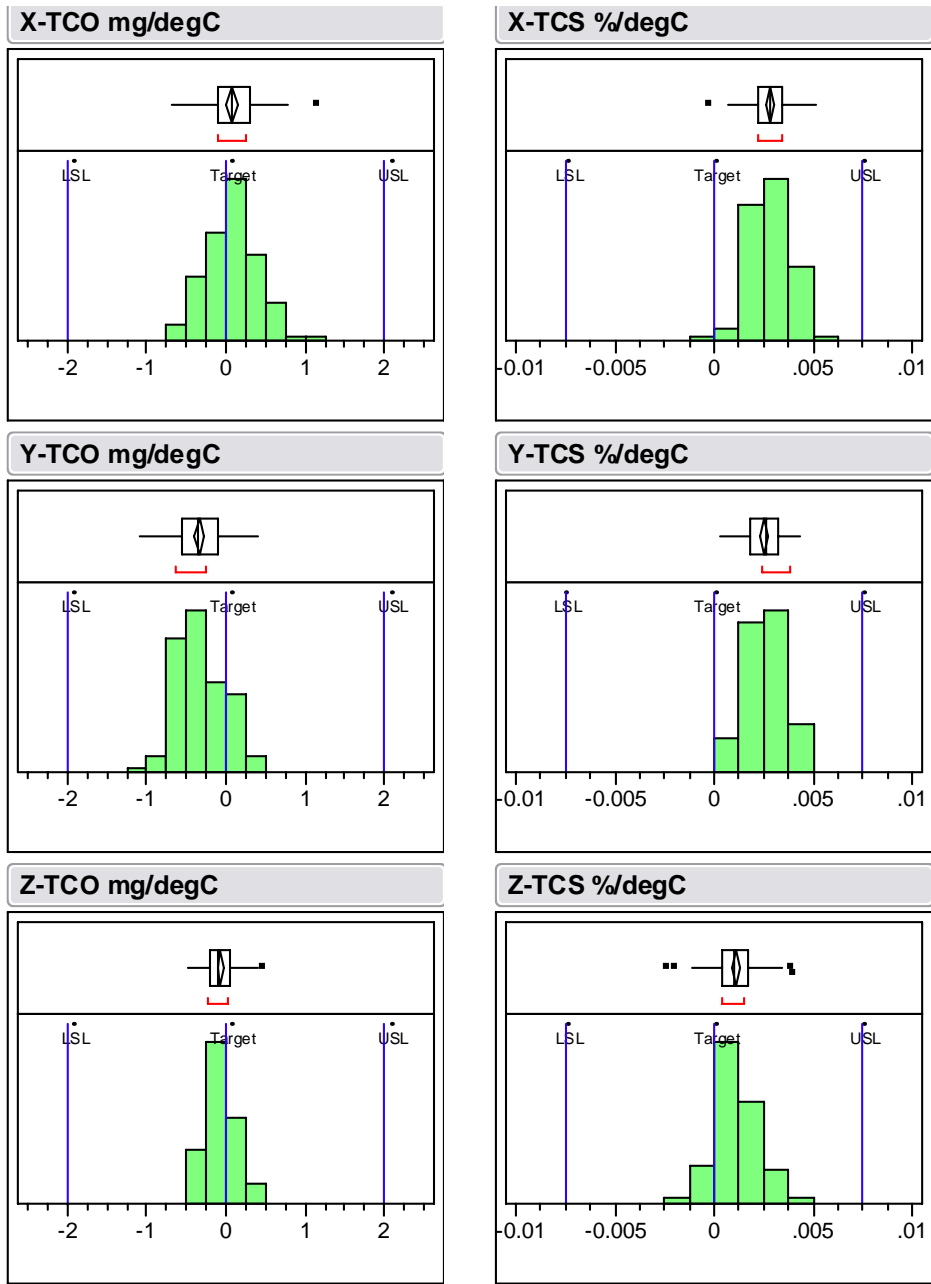

Figure 7. MMA7361LC Temperature Coefficient of Offset (TCO) and Temperature Coefficient of Sensitivity (TCS) Distribution Charts

## MINIMUM RECOMMENDED FOOTPRINT FOR SURFACE MOUNTED APPLICATIONS

### PCB Mounting Recommendations

MEMS based sensors are sensitive to Printed Circuit Board (PCB) reflow processes. For optimal zero-g offset after PCB mounting, care must be taken to PCB layout and reflow conditions. Reference application note AN3484 for best practices to minimize the zero-g offset shift after PCB mounting.

Surface mount board layout is a critical portion of the total design. The footprint for the surface mount packages must be the correct size to ensure proper solder connection interface between the board and the package.

With the correct footprint, the packages will self-align when subjected to a solder reflow process. It is always recommended to design boards with a solder mask layer to avoid bridging and shorting between solder pads.

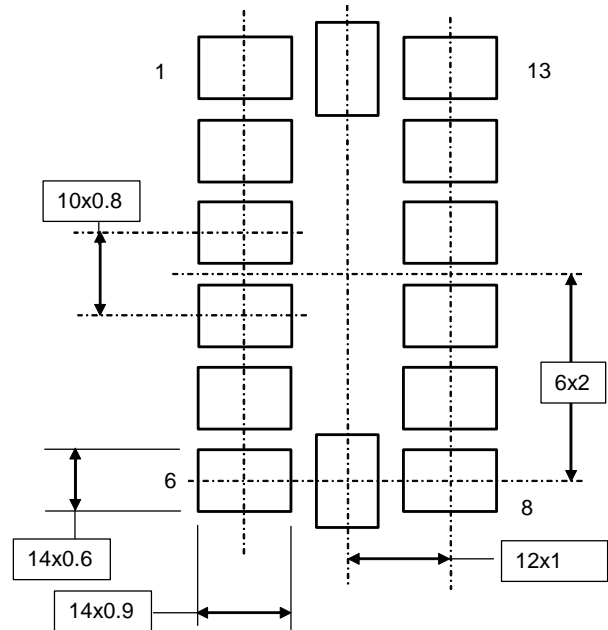



# PACKAGE DIMENSIONS

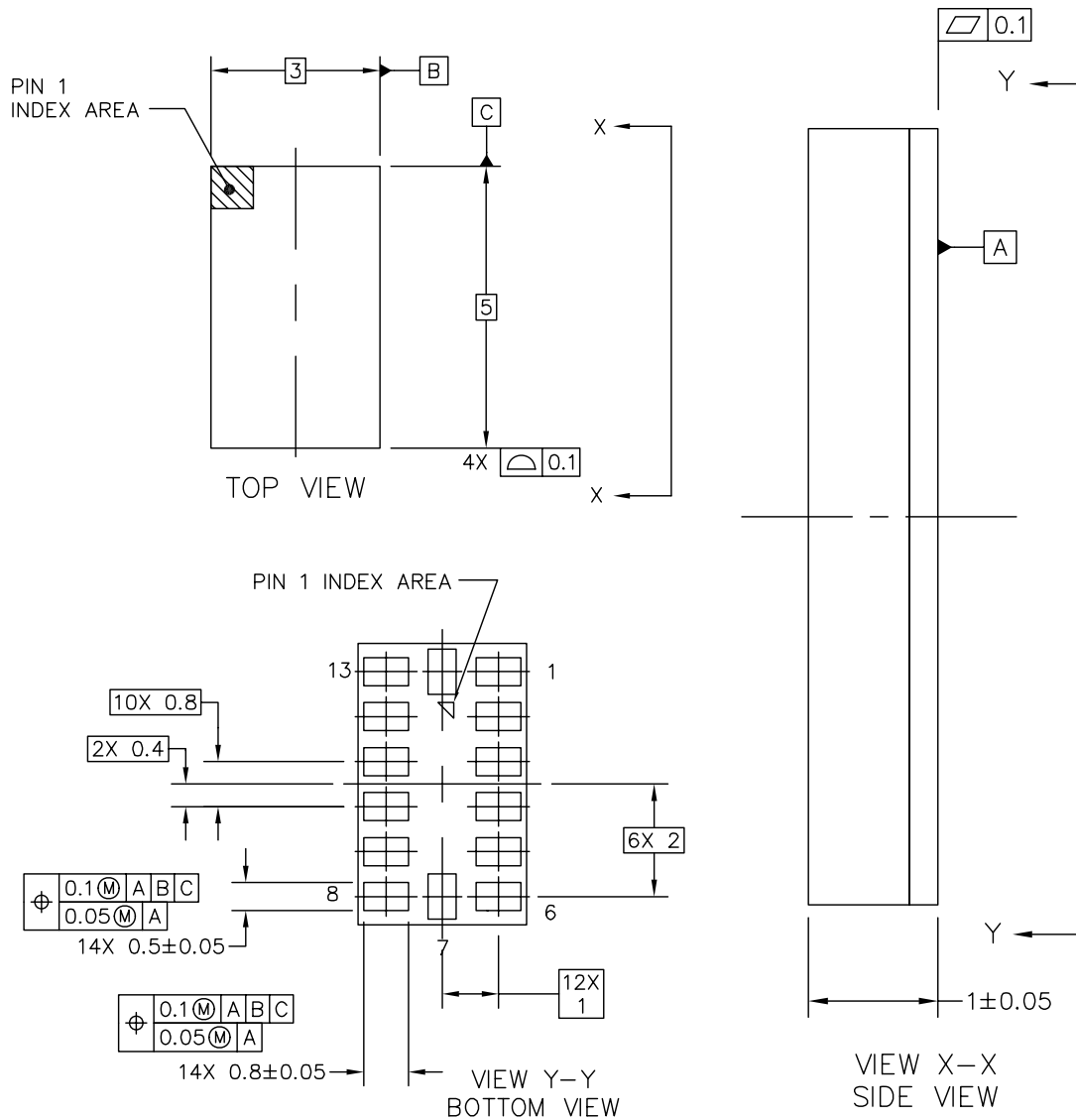

© FREESCALE SEMICONDUCTOR, INC. ALL RIGHTS RESERVED.	<b>MECHANICAL OUTLINE</b>	PRINT VERSION NOT TO SCALE
TITLE: LGA 14 I/O, 3 X 5 X 1 PITCH 0.8, SENSOR 1.0MM PKG	DOCUMENT NO: 98ASA10801D	REV: A
	CASE NUMBER: 1977-01	09 JAN 2008
	STANDARD: NON-JEDEC	

**CASE 1977-01  
ISSUE A  
14-LEAD LGA**

## PACKAGE DIMENSIONS

NOTES:

1. ALL DIMENSIONS IN MILLIMETERS.
2. DIMENSIONING AND TOLERANCING PER ASME Y14.5M-1994.

© FREESCALE SEMICONDUCTOR, INC. ALL RIGHTS RESERVED.	<b>MECHANICAL OUTLINE</b>	PRINT VERSION NOT TO SCALE	
TITLE: LGA 14 I/O, 3 X 5 X 1 PITCH 0.8, SENSOR 1.0MM PKG	DOCUMENT NO: 98ASA10801D	REV: A	
	CASE NUMBER: 1977-01	09 JAN 2008	
	STANDARD: NON-JEDEC		

**CASE 1977-01  
ISSUE A  
14-LEAD LGA**

## **How to Reach Us:**

### **Home Page:**

[www.freescale.com](http://www.freescale.com)

### **Web Support:**

<http://www.freescale.com/support>

### **USA/Europe or Locations Not Listed:**

Freescale Semiconductor, Inc.  
Technical Information Center, EL516  
2100 East Elliot Road  
Tempe, Arizona 85284  
+1-800-521-6274 or +1-480-768-2130  
[www.freescale.com/support](http://www.freescale.com/support)

### **Europe, Middle East, and Africa:**

Freescale Halbleiter Deutschland GmbH  
Technical Information Center  
Schatzbogen 7  
81829 Muenchen, Germany  
+44 1296 380 456 (English)  
+46 8 52200080 (English)  
+49 89 92103 559 (German)  
+33 1 69 35 48 48 (French)  
[www.freescale.com/support](http://www.freescale.com/support)

### **Japan:**

Freescale Semiconductor Japan Ltd.  
Headquarters  
ARCO Tower 15F  
1-8-1, Shimo-Meguro, Meguro-ku,  
Tokyo 153-0064  
Japan  
0120 191014 or +81 3 5437 9125  
[support.japan@freescale.com](mailto:support.japan@freescale.com)

### **Asia/Pacific:**

Freescale Semiconductor Hong Kong Ltd.  
Technical Information Center  
2 Dai King Street  
Tai Po Industrial Estate  
Tai Po, N.T., Hong Kong  
+800 2666 8080  
[support.asia@freescale.com](mailto:support.asia@freescale.com)

### **For Literature Requests Only:**

Freescale Semiconductor Literature Distribution Center  
1-800-441-2447 or 303-675-2140  
Fax: 303-675-2150  
[LDCForFreescaleSemiconductor@hibbertgroup.com](mailto:LDCForFreescaleSemiconductor@hibbertgroup.com)

Information in this document is provided solely to enable system and software implementers to use Freescale Semiconductor products. There are no express or implied copyright licenses granted hereunder to design or fabricate any integrated circuits or integrated circuits based on the information in this document.

Freescale Semiconductor reserves the right to make changes without further notice to any products herein. Freescale Semiconductor makes no warranty, representation or guarantee regarding the suitability of its products for any particular purpose, nor does Freescale Semiconductor assume any liability arising out of the application or use of any product or circuit, and specifically disclaims any and all liability, including without limitation consequential or incidental damages. "Typical" parameters that may be provided in Freescale Semiconductor data sheets and/or specifications can and do vary in different applications and actual performance may vary over time. All operating parameters, including "Typicals", must be validated for each customer application by customer's technical experts. Freescale Semiconductor does not convey any license under its patent rights nor the rights of others. Freescale Semiconductor products are not designed, intended, or authorized for use as components in systems intended for surgical implant into the body, or other applications intended to support or sustain life, or for any other application in which the failure of the Freescale Semiconductor product could create a situation where personal injury or death may occur. Should Buyer purchase or use Freescale Semiconductor products for any such unintended or unauthorized application, Buyer shall indemnify and hold Freescale Semiconductor and its officers, employees, subsidiaries, affiliates, and distributors harmless against all claims, costs, damages, and expenses, and reasonable attorney fees arising out of, directly or indirectly, any claim of personal injury or death associated with such unintended or unauthorized use, even if such claim alleges that Freescale Semiconductor was negligent regarding the design or manufacture of the part.

Freescale™ and the Freescale logo are trademarks of Freescale Semiconductor, Inc., Reg. U.S. Pat. & Tm. Off. All other product or service names are the property of their respective owners.

© Freescale Semiconductor, Inc. 2010. All rights reserved.

RoHS-compliant and/or Pb-free versions of Freescale products have the functionality and electrical characteristics of their non-RoHS-compliant and/or non-Pb-free counterparts. For further information, see <http://www.freescale.com> or contact your Freescale sales representative.

For information on Freescale's Environmental Products program, go to <http://www.freescale.com/epp>.