

SECTION A-A

NOTE

MATERIAL:

- 1. 1-1 HOUSING: LCP UL94V-0
- 1-2 CONTACT: 1~4PIN,COPPER(T=0.20MM)
5~9PIN,BTASS(T=0.20MM)
- 1-3 SHELL: FRONT SHELL,BRASS(T=0.30MM)
COVER SHELL,SPCC(T=0.20MM)

2.ELECTRICAL CHARACTERISTICS:

- 2.1 CONTACT RESISTANCE:30MOHM MAX.
- 2.2 CONTACT CURRENT RATING:1.5A
- 2.3 DIELECTRIC WITHSTANDING VOLTAGE:500 V R.M.S.
- 2.4 INSULATION RESISTANCE 1000 MEGOHMS MIN.
- 2.5 OPERATING TEMPERATURE:-40°C~85°C

3.MECHANICAL CHARACTERISTICS:

- 3.1 MATING FORCE:3.57KG MAX.
- 3.2 UNMATING FORCE:1.02KG MIN.
- 3.3 DURABILITY:MANDATORY:5000 CYCLES.

4.PLATING

- 4.1 TERMINAL:GOLD FLASH ALL OVER 50U"MIN
NICKEL AND 1U"MIN TIN ALL OVER 50U"MIN.
NICKEL ON SOLDER AREA
- 4.2 SHELL:150U" MIN.NICEL OVER 20U"MIN BRASS.

12 4- 09 2 5 N X XX 02

CONTACT PLATING COD:
A=1u" B=3u" C=5u"
E=15u" F=30u" O=0.5u"

STANDARD
HOUSING COLOR:
05=BLUE -----

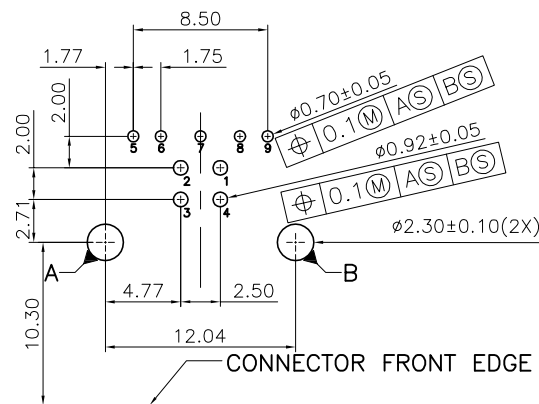
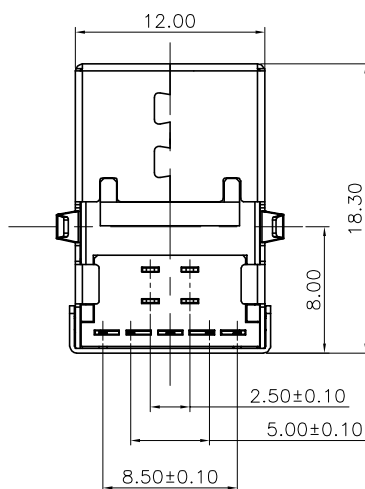

RECOMMENDED PCB ALAYOUT

10/06/09	ING		NEW DWG		AO
DATE	DR.BY	ECN.NO.	DESCRIPTION		MARK VER.
-TOLERANCES- UNLESS OTHERWISE SPECIFIED 公差参考表			D.		
			TITLE: USB 3.0 B TYPE FEMALE DIP90度成品		
X.X	±0.38	X.X'	±2'	APPD:	PRODUCT NO: 124-0925XXXX02
X.XX	±0.25	X.XX'	±1'	CHECK:	DATE SCALE UNIT TYPE PAGE
X.XXX	±0.10	X.XXX'	±0.5'	DRAW:	2010.06.09 1:1 mm Z 1/1