

ATTEN INSTRUMENTS

- RF Microwave Instruments • RF Microwave Components
- Spectrum Analyzers • Regulated DC Power Supply
- Regulated AC Power Supply • Switching DC Power Supply
- Digital Storage Oscilloscope • Signal Generator • Attenuator • Amplifier
- 850 Rework Station • 936 Constant Temp Soldering Station
- Electronic Instruments • Electronic Tools

FRANCHISER



USER'S MANUAL



SHENZHEN ATTEN ELECTRONICS CO., LTD.
MFR Add: Building A29, Tangliang Industrial
Zone, Xili, Nanshan, Shenzhen, 518055, P. R. China
Tel: 86-755-8602 1373 8602 1372 Fax: 86-755-8602 1337
<http://www.atten.com.cn> E-mail: atten@atten.com.cn

SHENZHEN ATTEN ELECTRONICS CO., LTD.
© 2010 Atten Corporation

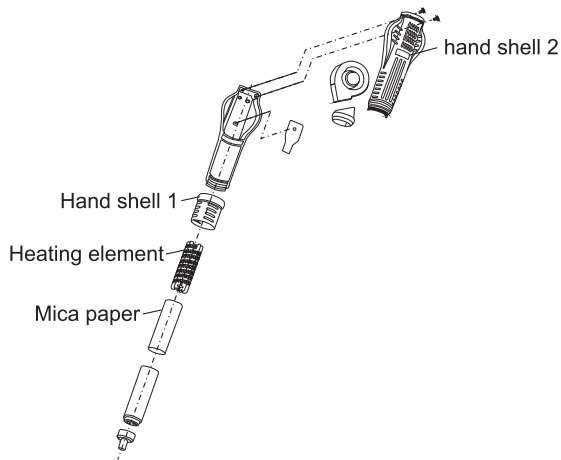

Accessories list

Main device and handle of the rework station	One desk
Handle frame	One set
Soldering iron	One piece
Iron holder	One set
Power line	One article
Using manual	One piece

⚠ Thank you for choosing our products, before operation, please read this manual carefully.

AT8586 is a rework tools that combined heat gun and soldering station perfectly. Not only does it operate simply and comfortable, but save room largely.

Rules of Safety

Using this device, you must abide by the following measures in order not to get an electric shock, result in damages to people or result in fire, etc.

1. In order to secure the safety of people, you must use the parts or accessories that the factory of origin certificates or recommends; or it will lead to serious aftermaths.
2. This rework station must be repaired by qualified technicians or the appointed person by us.
3. This device makes use of three-wire grounding plug, should plug it into three-hole grounding outlet. Do not change the outlet or ungrounded adapter which would lead to being bad ground.
4. be careful, for it is operated at a high temperature which is more than 400°C. Don't use it near flammable and explosive gas and objects, for the tip and the air from it are steaming-hot, which can burn people. Don't touch the heating element or spray the hot air against people.
5. When the hot air rework station starts to work, don't leave from your post.
6. When it starts to work, don't install the nozzle until the heating pipe and nozzle are cooled
7. Please keep the draughts of input and output expedites; there should be no block.
8. After using it, remember to cool the machine. You should put the handle into the handle frame. When the machine is in the waiting state, you can make the power off.
9. Do not use the iron tip to do anything except soldering. Do not make the iron beat table to Cleary the remains of flux, which will damage the iron badly.
10. When it was soldering, it will smoke. Please keep the work environment ventilation.

Product Characteristics

- ▶ Multifunctional Integrated Desoldering Maintenance System Combined by Rework Station and Soldering Station.
- ▶ The core of the whole machine controlled by the single and microwave chip to make sure of temperature accuracy and stability of rework station and soldering station; not simply combined by the two equipments.
- ▶ Clear digital display of the current working temperature and conditions
- ▶ Temperatures of rework station and soldering station continuously adjusted by digital buttons to meet the needs in different workplaces.
- ▶ The two stations can work separately.
- ▶ Intuitive fault indication function.

Product diagram

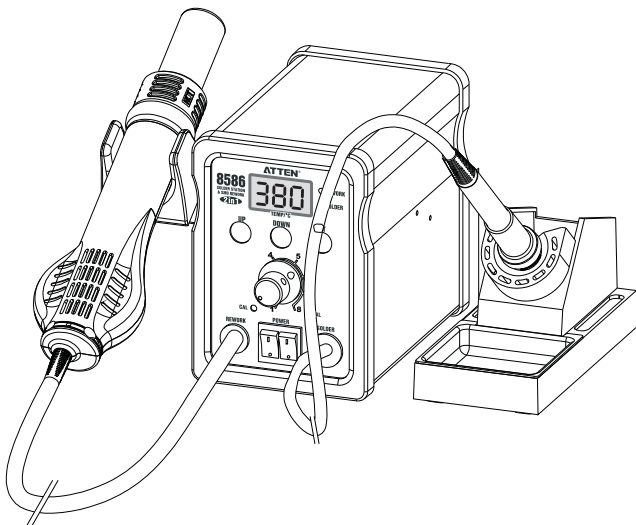

— 3 —

9. Rousing the hot air rework

Under the waiting state, display does not show state neither of the two channel. LED display shows the working state of soldering station & SMD rework and restores last time settings, as long as you hold the handle of the rework station again.

10. Symbol description

Display “- 1” means the rework station partly does not start that the heating cord is off.

Display “SLP” means the rework station enters the waiting mode.

Display “- 2” means the soldering station partly does not start that the heating cord is off.

Display “S-E” means there is something wrong with the sensor of the working channel, so the device stops outputting signal.

Display “H-E” means the heating elements of the channel may be damaged partly.

Bottom of the decimal point of the display: all are lighting which means heating; all snub out which means stopping heating; some is flicker means the temperature of one channel, at least, is stably.

11. Correcting temperature

You should correct temperature after changing the heating elements or iron tip. When you correct temperature, please use no sense and suitable screwdriver stretch into corresponding hole of “CAL”, then rotate fine tuning toward left or right.

Replacement of the heating element

Replace the heating element after they are cool and complete power-cutoff.

Step1. Release two fixed screws of the hand

Step2. Remove hand shell 1, and then hand shell 2.

Step3. Remove the fan gently, the take out fixed screw on the connected wire board.

Step4. Converse the board and disconnect the connecting wire of the heating element, pay attention to the position for the connecting wire.

Step5. Take out the damaged heating element from the steel tube, and replace the now. According to the contrary method, install the handle correctly.

— 8 —

2. Power

Open the master power switch at the back panel of the device after connected the power. In the case of two heat switch closed, LED display show the rework station in waiting state with “- -1”

3. Operate

Put on the heat switch, LED display show the current open sets. Three seconds later, display the actual work state. At same time, the heat channel shows indicator lights.

4. Stop working

Put off the heat switch of current working channel, it will stop heating. If LED previously displays working state of one channel, now it shows the other channel working state or waiting state.

5. Shut down

After using it, remember to cool the machine. You should put the handle on the shelf. When the machine is in the waiting state, you can make the power off, which will extend the service life of soldering station & SMD rework. If you don't use it, you should put the heat switch and master power switch at the back panel off.

6. Digital display conversion

On the condition of connected power, push the “SET” cord to transform between the two channels, and the connected channel show indicator lights.

7. Temperature setting

After connected power, if the display shows the state you need, you can directly press the “up” or “down” cord to converse the temperature of this channel. If not, you should press “SET” cord, then press “UP” or “DOWN” cord to converse temperature. Accomplish the display settings, three seconds later, display shows the actual work state.

8. The waiting state of hot air rework

If you do not use this device temporary and please put the handle on the handle frame, the device will cut down hot air. When the temperature is less than 100°C, the rework station becomes in waiting state. Now the state of LED display showing is the situation of soldering station & SMD rework. If the device come into operating state, the display will automatically converse to the state of soldering station & SMD rework, otherwise, it will show “SLP”, the waiting state.

Front panel diagram

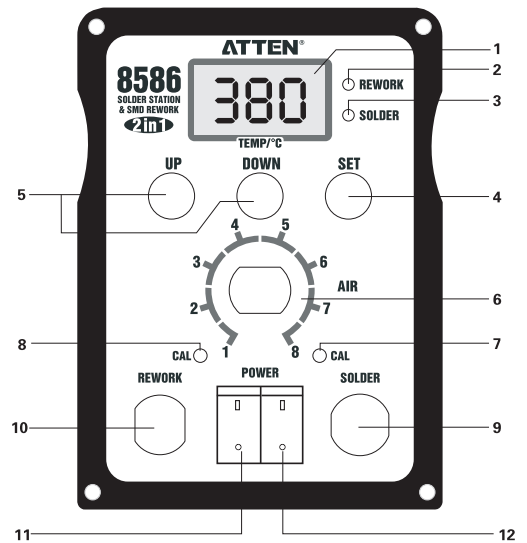

1. Temperature display
2. Rework station temperature display status indicator
3. Soldering station temperature display status indicator
4. Show status switch button
5. temperature adjustable button
6. Rework station hot air volume adjustable knob
7. Soldering station temperature correction
8. Rework station temperature correction
9. Soldering station output
10. Rework station output
11. Rework station heat switch
12. Soldering station heat switch

Back panel diagram

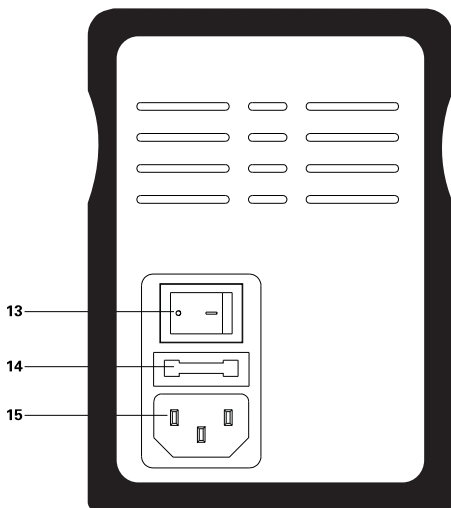

13. Power switch

14. Fuse

15. Outlet

Technical Specification

Rated Voltage: AC220V \pm 10% 50Hz

Power: 750W (max)

Rework Station

Working Voltage: AC220V \pm 10% 50Hz

Output Power: 700W

Temperature Range: 100°C–500°C

Temperature Stability: \pm 5°C

Air Flow: 120L/min (max)

Soldering Station

Working Voltage: AC26V 50Hz

Output Power: 50W

Temperature Range: 200°C–480°C

Temperature Stability: \pm 2°C (static)

Ground Impedance: $<$ 2 Ohm

Ground Voltage: $<$ 3mV

Operation instructions

1. Installation

When the new machine is operated for the first time, you must install the handle frame, the picture is as follows: According to your habits, you can screw the four screws tightly. Under your need, remove the two screws of the fixed handle shelf on the right or on the left. Put the two installation holes of the handle in the fixed screw holes, and screw the two removed screws tightly. Put the components of the handle on the frame and check if suitable.

